

AIR CONDITIONER

INSTALLATION MANUAL

For authorized service personnel only.

OPERATION MANUAL

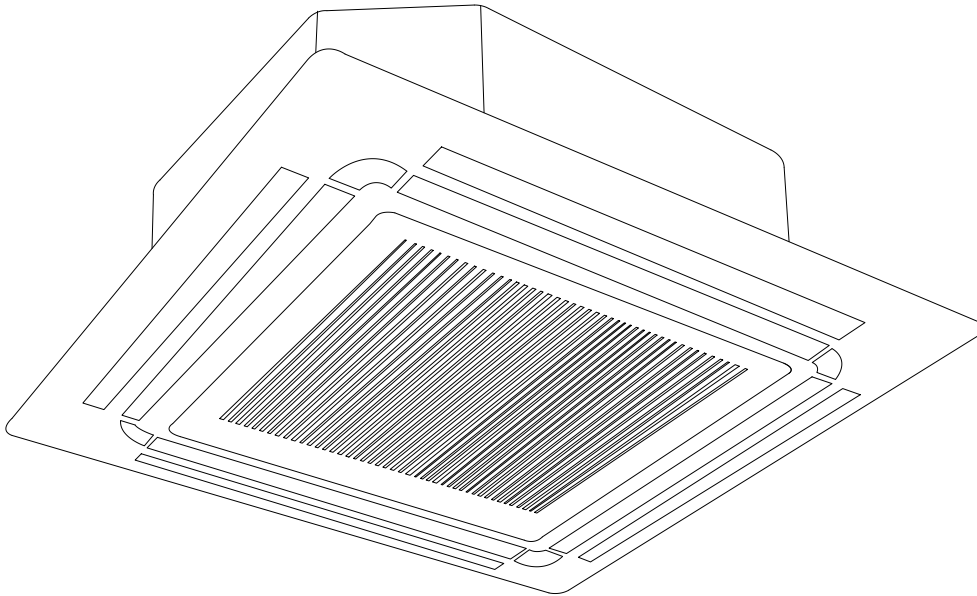

[Original instructions]
PART No. 22022510004883
22022510004824
22022510004904
22022510004843

INSTALLATION MANUAL

INDOOR UNIT (Cassette type)

Contents

1. SAFETY PRECAUTIONS	1
2. ABOUT THIS PRODUCT	1
2.1. Special tools for R410A/R32.....	1
2.2. Accessories	1
3. GENERAL SPECIFICATION	2
3.1. Selecting the pipe material	2
3.2. Pipe requirement	2
3.3. Electrical requirement	2
4. INSTALLATION WORK	2
4.1. Selecting an installation location.....	2
4.2. Installation dimension	3
4.3. Installing the unit	5
4.4. Installing the drain pipe	5
5. PIPE INSTALLATION	6
5.1. Flare connection (pipe connection)	6
6. ELECTRICAL WIRING	6
6.1. Wiring method	7
7. OUTDOOR INSTALLATION.....	7
8. CHECK LIST	11
9. TEST RUN.....	11
10. ERROR CODES.....	12
11. OPERATION MANUAL	13

Note: This manual describes how to install the air conditioner described above. Handling and installation shall only be done by professionals as outlined in this manual.

1. SAFETY PRECAUTIONS

- Be sure to read this manual thoroughly before installation.
- The warnings and precautions indicated in this Manual contain important information pertaining to your safety. Be sure to observe them.
- Hand this Manual, together with the operating manual, to the customer. Request the customer to keep them on hand for future use, such as for relocating or repairing the unit.

WARNING	Indicates a potentially or imminently hazardous situation which, if not avoided, could result in death or serious injury.
Installation of this product must be done by experienced service technicians or professional installers only in accordance with this manual. Installation by nonprofessional or improper installation of the product may cause serious accidents such as injury, water leakage, electric shock, or fire. If the product is installed in disregard of the instructions in this manual, it will void the manufacturer's warranty.	
Do not turn on the power until all work has been completed. Turning on the power before the work is completed can cause serious accidents such as electric shock or fire.	
If refrigerant leaks when you are working, ventilate the area. If the leaking refrigerant is exposed to a direct flame it may produce a toxic gas.	
Do not use this equipment with air or any other unspecified refrigerant in the refrigerant lines. Excess pressure can cause a rupture.	
Installation must be performed in accordance with regulations, codes, or standards for electrical wiring and equipment in each country, region, or the installation place.	
This appliance is not intended for use by persons (including children) with reduced physical, sensory or mental capabilities, or lack of experience and knowledge, unless they have been given supervision or instruction concerning use of the appliance by a person responsible for their safety. Children should be supervised to ensure that they do not play with the appliance.	

CAUTION

Indicates a potentially hazardous situation that may result in minor or moderate injury or damage to property.

Read carefully all safety information written in this manual before you install or use the air conditioner.

Install the product by following local codes and regulations in force at the place of installation, and the instructions provided by the manufacturer.

This product is part of a set constituting an air conditioner. The product must not be installed alone or be installed with non-authorized device by the manufacturer.

Always use a separate power supply line protected by a circuit breaker operating on all wires with a distance between contact of 3 mm for this product.

To protect the persons, earth (ground) the product correctly, and use the power cable combined with an Earth Leakage Circuit Breaker (ELCB).

This product is not explosion proof, and therefore should not be installed in explosive atmosphere.

Do not touch the fins of the heat exchanger. Touching the heat exchanger fins could result in damage to the fins or personal injury such as skin rupture.

To avoid getting an electric shock, never touch the electrical components soon after the power supply has been turned off. After turning off the power, always wait 5 minutes or more before you touch the electrical components.

This product contains no user-serviceable parts. Always consult experienced service technicians for repairing.

When moving or relocating the air conditioner, consult experienced service technicians for disconnection and reinstallation of the product.

Do not place any other electrical products or household belongings under the product. Condensation dripping from the product might get them wet, and may cause damage or malfunction to the property.

2. ABOUT THIS PRODUCT

2. 1. Special tools for R410A/R32

Tool name	R32 / R410A
Gauge manifold	Pressure is high and cannot be measured with a R22 gauge. To prevent erroneous mixing of other refrigerants, the diameter of each port has been changed. It is recommended to use gauge with seals -0.1 to 5.3 MPa (-1 to 53 bar) for high pressure. -0.1 to 3.8 MPa (-1 to 38 bar) for low pressure.
Charge hose	To increase pressure resistance, the hose material and base size were changed. (R410A/R32)
Vacuum pump	A conventional vacuum pump can be used by installing a vacuum pump adapter. (Use of a vacuum pump with a series motor is prohibited.)
Gas leakage detector	Special gas leakage detector for HFC refrigerant R410A/R32

Copper pipes

It is necessary to use seamless copper pipes and it is desirable that the amount of residual oil is less than 40 mg/10 m. Do not use copper pipes having a collapsed, deformed or discolored portion (especially on the interior surface). Otherwise, the expansion valve or capillary tube may become blocked with contaminants. As an air conditioner using R410A/R32 incurs pressure higher than when using R22, it is necessary to choose adequate materials.

WARNING





- Use specified R410A/R32 piping only. For indoor units, use R410A/R32 flare less joint nut assy only. For outdoor units, use R410A flare nuts only. Use of pipes, flare less nuts or flare nuts other than specified, may cause product malfunction, burst piping, or injury due to high internal pressure of the refrigerant cycle caused by any inflow air.
- Use (refill or replace with) specified refrigerant (R410A) only. Use of unspecified refrigerant can cause product malfunction, burst, or injury.
- Do not mix any gas or impurities except specified refrigerant (R410A). Inflow of air or application of unspecified material makes the internal pressure of the refrigerant cycle too high, and may cause product malfunction, burst of piping, or injury.

2. 2. Accessories

WARNING

For installation purposes, be sure to use the parts supplied by the manufacturer or other prescribed parts. The use of non-prescribed parts can cause serious accidents such as the unit falling, water leakage, electric shock, or fire.

- The following installation parts are furnished. Use them as required.
- Keep the installation manual in a safe place and do not discard any other accessories until the installation work has been completed.

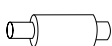
Name and Shape	Q'ty	Description
Installation manual 	1	(This book)
Template (Carton top) 	1	For installing indoor unit
Washer	8	For installing indoor unit
Coupler heat insulation (Large) 	1	For indoor side pipe joint (Gas pipe)
Coupler heat insulation (Small) 	1	For indoor side pipe joint (Liquid pipe)
Insulation 	1	For installing drain pipe
Drain hose 	1	For installing drain pipe VP25 (O.D.32, I.D.25)
Hose Band	1	For installing drain hose
Cable tie (Large)	4	For connection pipe fixing.
Cable tie (Small)	1	Only one is used for this model.

When flammable refrigerant are employed, appliance shall be stored in a well-ventilated area where the room size corresponds to the room area as specified for operation. For R32 refrigerant models: Appliance shall be installed, operated and stored in a room with a floor area larger than $X \text{ m}^2$. Appliance shall not be installed in an unventilated space, if that space is smaller than $X \text{ m}^2$ (Please see the following form).

Model (Btu/h)	Amount of refrigerant to be charged (kg)	Installation height	Minimum room area (m^2)
≤ 12000	≤ 1.11	2.2m	1
18000	≤ 1.65	2.2m	2
24000	≤ 2.58	2.2m	5
30000	≤ 3.08	2.2m	7
36000	≤ 3.84	2.2m	10
42000-48000	≤ 4.24	2.2m	12
55000-60000	≤ 4.39	2.2m	13

3. GENERAL SPECIFICATION

3.1. Selecting the pipe material

CAUTION

Do not use existing pipes.

Use pipes that have clean external and internal sides without any contamination which may cause trouble during use, such as sulfur, oxide, dust, cutting waste, oil, or water.

Do not use copper pipes that have a collapsed, deformed, or discolored portion (especially on the interior surface). Otherwise, the expansion valve or capillary tube may become blocked with contaminants.

Improper pipe selection will degrade performance. As an air conditioner using R410A/R32 incurs pressure higher than when using conventional refrigerant, it is necessary to choose adequate materials.

- Thickness of copper pipes used are as shown in the table.
- Never use copper pipes thinner than those indicated in the table even if they are available on the market.

Pipe outside diameter [mm (in.)]	Thickness [mm]
6.35 (1/4)	0.8
9.52 (3/8)	0.8
12.70 (1/2)	0.8
15.88 (5/8)	1.0
19.05 (3/4)	1.2

3.2. Pipe requirement

Refer to the installation manual of the outdoor unit for description of the length of connecting pipe or for difference of its elevation.

Inverter Cassette Type (kBtu)	Diameter [mm (in.)]	
	Liquid	Gas
18/24	6.35 (1/4)	12.70 (1/2)
36/48	9.52(3/8)	15.88(5/8)

• Additional refrigerant:

Inverter Cassette Type (kBtu)	Piping [m]		
	Max. Length	Max. Elevation	Additional Ref.
18/24	82m	50m	12g/m
36	98m	65m	24g/m
48	164m	98m	24g/m

- Use pipe with water-resistant heat insulation.

CAUTION

- Install heat insulation around both the gas and liquid pipes.
- Use heat insulation with heat resistance above $120 \text{ }^\circ\text{C}$. (Reverse cycle model only) In addition, if the humidity level at the installation location of the refrigerant piping is expected to exceed 70 %, install heat insulation around the refrigerant piping.
- If the expected humidity level is 70-80 %, use heat insulation that is 15 mm or thicker and if the expected humidity exceeds 80 %, use heat insulation that is 20 mm or thicker.
- If heat insulation is used that is not as thick as specified, condensation may form on the surface of the insulation. In addition, use heat insulation with heat conductivity of $0.045 \text{ W/(m}\cdot\text{K)}$ or less (at $20 \text{ }^\circ\text{C}$).

3.3. Electrical requirement

Unit can be powered .

Indoor Unit: 220/1/50 - 380/50/3 (Following the specification for detail)

Outdoor: 220/50/1 - 380/50/3 (Following the specification for detail)

WARNING

- BEFORE PERFORMING ANY ELECTRICAL OR WIRING WORK, TURN OFF THE MAIN POWER TO THE SYSTEM.
- STANDARD FOR ELECTRICAL WIRING AND EQUIPMENT DIFFERS IN EACH COUNTRY OR REGION. BEFORE YOU START ELECTRICAL WORKING, CONFIRM RELATED REGULATIONS, CODES, OR STANDARDS.

Minimum Cross-Sectional Area of Power and Signal Cables (For reference)

Rated Current (A)	Nominal Cross-Sectional Area (mm^2)
> 3 and ≤ 6	1.5 (minimum)
> 6 and ≤ 10	1.5 (minimum)
> 10 and ≤ 16	1.5 (minimum)
> 16 and ≤ 25	2.5 (minimum)
> 25 and ≤ 32	6.0 (minimum)
> 32 and ≤ 40	10.0 (minimum)

Type 60245 IEC57

Max. Cable Length: Limit voltage drop to less than 2%. Increase cable gauge if voltage drop is 2% or more.

Cable	Conductor size (mm^2)	Type	Remarks
Connection cable	1.5 (MIN.)	Type 60245 IEC57	3Wire+Earth (Ground), $1\phi 230\text{V}$

Cable	Conductor size (mm^2)	Type	Remarks
Remote controller cable (2-wire type)	0.65 to 1.25	Sheathed PVC cable	Non-polar 2 wire
Remote controller cable (3 or 5-wire type)	0.33 to 0.65	Sheathed PVC cable	Polar 3 or 5 wire

4. INSTALLATION WORK

WARNING

Do not turn on the power until all installation work is complete.

Carrying and installation of the unit should be performed by a sufficient number of people and with sufficient equipment that is adequate for the weight of the unit.

Performing such work with an insufficient number of people or with inadequate equipment could result in dropping of the unit or personal injury.

4.1. Selecting an installation location

Decide the mounting position together with the customer as follows.

WARNING

R.E.E ELECTRIC APPLIANCES JSC

Select installation locations that can properly support the weight of the indoor unit and which will not amplify sound or vibration. If the installation location is not strong enough, the indoor unit may fall and cause injuries.

Install the units securely so that they do not topple or fall.

CAUTION

Do not install the indoor unit in the following areas:

- Area with high salt content, such as at the seaside. It will deteriorate metal parts, causing the parts to fall or the unit to leak water.
- Area filled with mineral oil or containing a large amount of splashed oil or steam, such as a kitchen. It will deteriorate plastic parts, causing the parts to fall or the unit to leak water.
- Area that generates substances that adversely affect the equipment, such as sulfuric gas, chlorine gas, acid, or alkali. It will cause the copper pipes and brazed joints to corrode, which can cause refrigerant leakage.
- Area that can cause combustible gas to leak, contains suspended carbon fibers or flammable dust, or volatile inflammables such as paint thinner or gasoline. If gas leaks and settles around the unit, it can cause a fire.
- Area where animals may urinate on the unit or ammonia may be generated.

Do not use the unit for special purposes, such as storing food, raising animals, growing plants, or preserving precision devices or art objects. It can degrade the quality of the preserved or stored objects.

Do not install where there is the danger of combustible gas leakage.

Do not install the unit near a source of heat, steam, or flammable gas.

Install the unit where drainage does not cause any trouble.

Install the indoor unit, outdoor unit, power supply cable, transmission cable, and remote control cable at least 1 m away from a television or radio receivers. The purpose of this is to prevent TV reception interference or radio noise. (Even if they are installed more than 1 m apart, you could still receive noise under some signal conditions.)

Install the unit where ambient temperature does not reach 60°C or more. Take a measure such as ventilation for an environment in which heat is retained. If children under 10 years old may approach the unit, take preventive measures so that they cannot reach the unit.

Install the indoor unit on the place where the height from the floor is more than 1.8 m. when the condition under the roof is over 80% in humidity and over 30°C in temperature. Otherwise, there is a risk of condensation on the ceiling.

Installation flow

- (1) Locate where the air can be distributed evenly throughout the room by the unit.
- (2) The inlet and outlet ports should not be obstructed; the air should be able to blow all over the room.
- (3) Leave the space required to service the air conditioner.
- (4) Install the unit where connection to the outdoor unit is easy.
- (5) Install the unit where the connection pipe can be easily installed.
- (6) Install the unit where the drain pipe can be easily installed.
- (7) Install the unit where noise and vibrations are not amplified.
- (8) Take servicing, etc., into consideration and leave the spaces. Also install the unit where the filter can be removed.
- (9) Do not install the unit where it will be exposed to direct sunlight.

4. 2. Installation dimension

Distance from ceiling relative to height of indoor unit

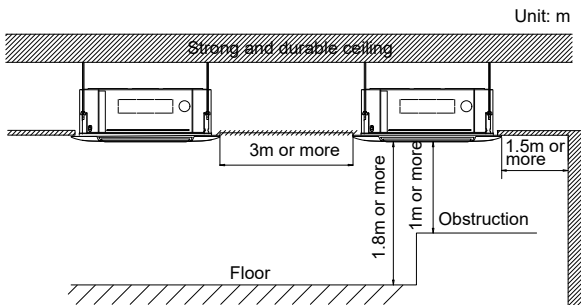

• This product can be installed at a height of up to 4.2 m. However, if the heights of the ceiling is higher than 3.2 m or lower than 2.7 m, it is necessary to set the position from remote controller.

Distance from ceiling relative to height of indoor unit

TYPE	Capacity	A (mm/inch)	H (mm/inch)	B (mm/inch)
Super-Slim Model	18-24	205/8	> 235/9.3	880/34.5
	24	245/9.6	> 275/10.8	
	30	205/8	> 235/9.3	
	30-48	245/9.6	> 275/10.8	
	48-60	287/11.3	> 317/12.5	
Compact Model	48-60	287/11.3	> 317/12.5	940/37.0
	18-24	260/10.2	> 290/11.4	600/23.6
Standard Model	18-24	205/8.03	> 230/9.06	900/35.4
	30-36	245/9.65	> 271/10.7	
	48-60	287/11.3	> 313/12.3	

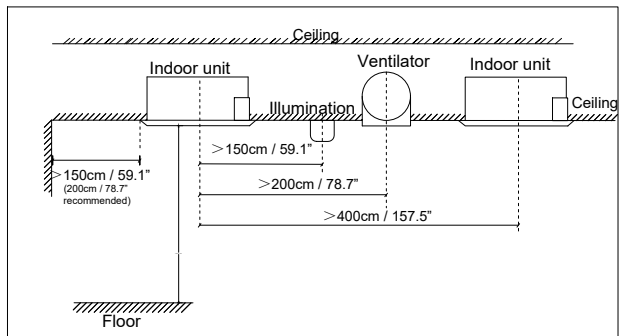
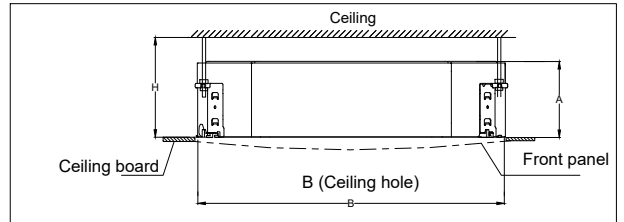

4.3.1. Position the ceiling hole and hanging bolts

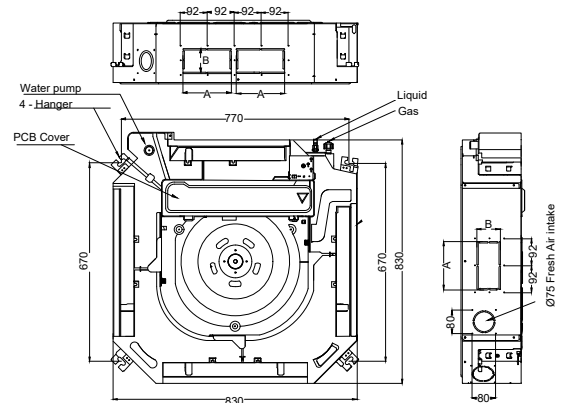

Model (K Btu/h)	Unit	A	B
18~24	mm	165	80
36~48	mm	165	100

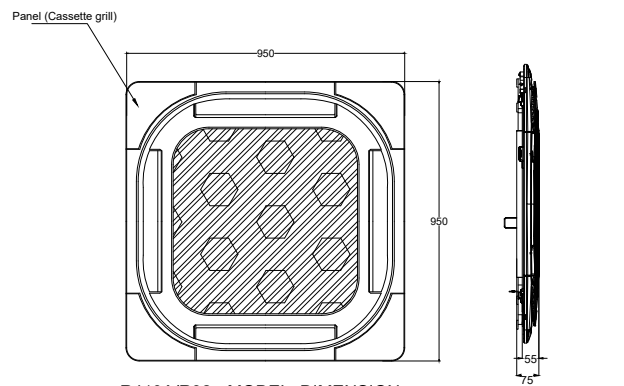

R410A/R32 - MODEL DIMENSION

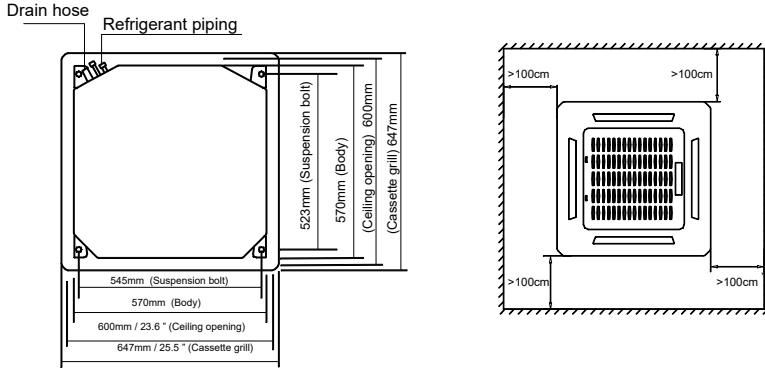
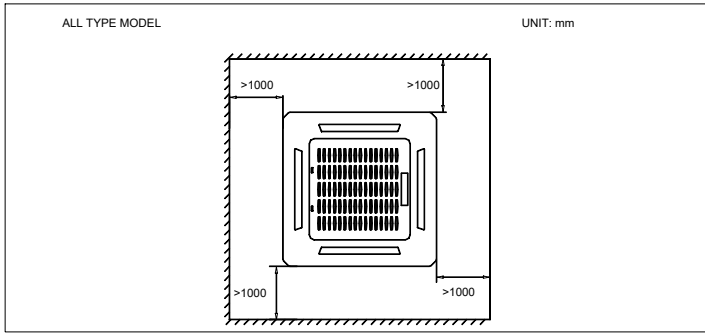

COMPACT MODELS CEILING HOLE SIZE

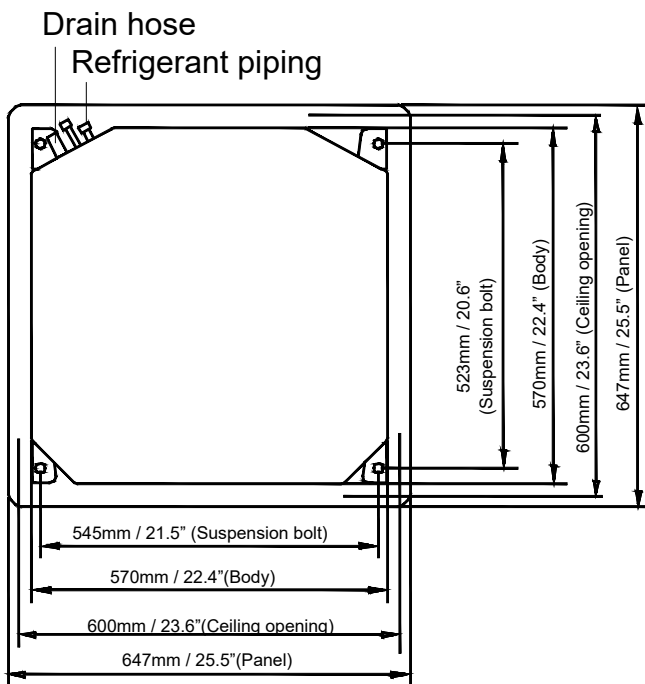

POSITION THE CEILING HOLE AND HANGING BOLTS

4. 3. Installing the unit

WARNING

Carrying and installation of the unit should be performed by a sufficient number of people and with sufficient equipment that is adequate for the weight of the unit. Performing such work with an insufficient number of people or with inadequate equipment could result in dropping of the unit or personal injury.

If the job is done with the panel frame only, there is a risk that the unit will come loose. Please take care.

When fastening the hangers, make the bolt positions uniform.

- (1) Setting the positions of hanging bolt and ceiling opening.
 - Use an installation template (packaging top surface) to set the positions of the hanging bolt and ceiling opening and drill holes.
- (2) Hanging structure.
 - Select a strong structure for the hanging location.
 - If necessary, reinforce the hanging bolt with quake proof columnar support material to prevent shaking.
 - Use hanging bolts of M8-M10.

4.3.2. Body installation

- (1) Install the attached washer and nut (prepared on site) onto the hanging bolt.
- (2) Hook the body onto the hanging bolt.
- (3) Adjust the dimensions of the ceiling surface from the body. After installing the Cassette grille, you can make fine adjustment of the height of the body. For details, refer to the installation manual of the Cassette grille.

WARNING

Perform final tightening by tightening the double nut firmly.

Be sure to install the body horizontally and adjust the height below the body and the ceiling surface properly.

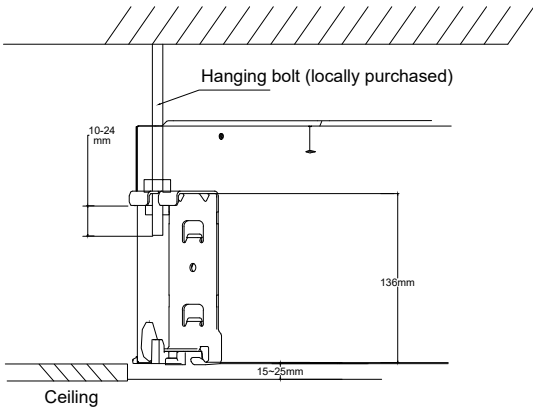

4.3.3. Leveling

Using a level, or vinyl hose filled with water, fine adjust so that the body is level. Inclined installation so as the drain pipe side is higher may cause a malfunction of the float switch, and may cause water leakage.

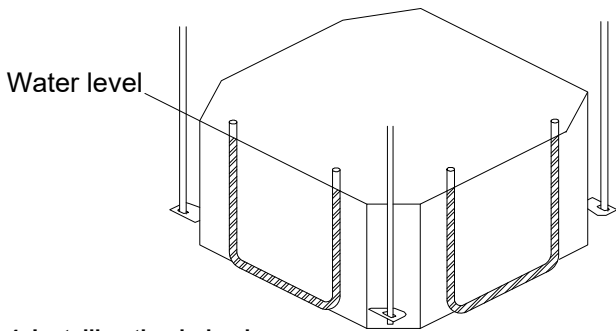

4. 4. Installing the drain pipe

WARNING

Do not insert the drain piping into the sewer where sulfurous gas occurs. (Heat ex-change erosion may occur.)

Insulate the parts properly so that water will not drip from the connection parts. Check for proper drainage after the construction by using the visible portion of transparent drain port and the drain piping final outlet on the body.

CAUTION

Do not apply adhesive agent on the drain port of the body. (Use the attached drain hose and connect the drain piping.)

Install the drain pipe:

- Install the drain pipe with downward gradient (1/50 to 1/100) and so there are no rises or traps in the pipe.
- Use general hard polyvinyl chloride pipe (VP25) [outside diameter 32 mm] and connect it with adhesive (polyvinyl chloride) so that there is no leakage.
- When the pipe is long, install supporters.
- Do not perform air bleeding.
- Always heat insulate the indoor side of the drain pipe.
- If it is impossible to have sufficient gradient of pipe, perform drain lift-up.

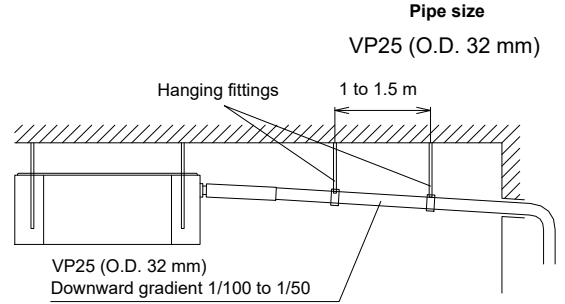

PROHIBITED:

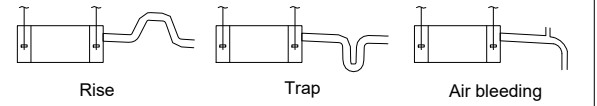

When lifting up drain:

- Height of inclined pipe should be less than 850 mm from the ceiling. A rise dimension over this range will cause leakage.
- Lift up the pipe vertically at the position of 300 mm or less from the unit.

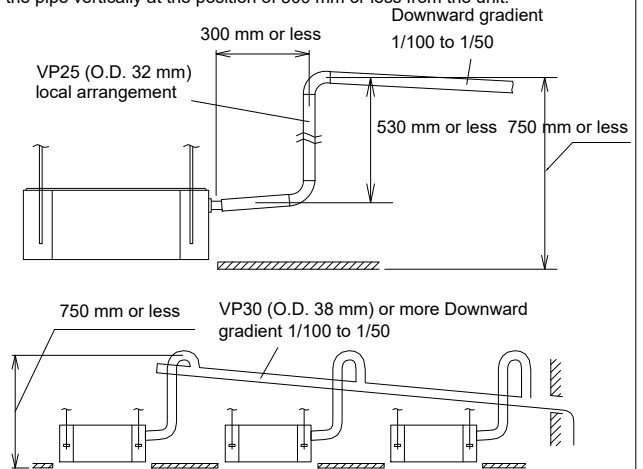

Working procedure

- (1) Install the attached drain hose to the drain port of the body. Attach hose band on top of the drain hose.
- (2) Use vinyl adhesive agent to glue the drain piping (PVC pipe VP25) which is prepared on site or elbow socket. (Apply color adhesive agent evenly until the gauge line and seal.)
- (3) Check the drainage.
- (4) Install the heat insulation.
- (5) Use the attached heat insulation to insulate the drain port and band parts of the body.

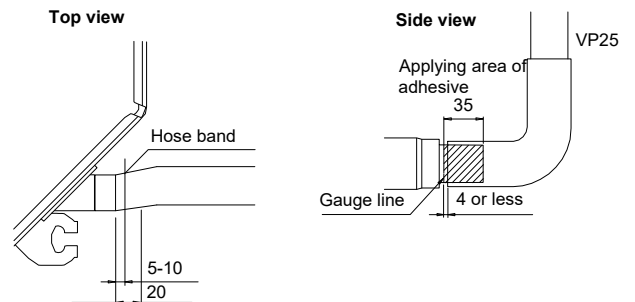

5. PIPE INSTALLATION

WARNING

During installation, make sure that the refrigerant pipe is attached firmly before you run the compressor.

Do not operate the compressor under the condition of refrigerant piping not attached properly with 2-way or 3-way valve open. This may cause abnormal pressure in the refrigeration cycle that leads to breakage and even injury.

During the pump-down operation, make sure that the compressor is turned off before you remove the refrigerant piping.

Do not remove the connection pipe while the compressor is in operation with 2-way or 3-way valve open. This may cause abnormal pressure in the refrigeration cycle that leads to breakage and even injury.

When installing and relocating the air conditioner, do not mix gases other than the specified refrigerant R410A/R32 to enter the refrigerant cycle.

If air or other gas enters the refrigerant cycle, the pressure inside the cycle will rise to an abnormally high value and cause breakage, injury, etc.

If refrigerant leaks while work is being carried out, ventilate the area. If the refrigerant comes in contact with a flame, it produces a toxic gas.

CAUTION

Be more careful so that foreign matter (oil, water, etc.) does not enter the piping than with refrigerant R410A/R32 models. Also, when storing the piping, securely seal the openings by pinching, taping, etc.

While brazing the pipes, be sure to purge with dry nitrogen gas.

5. 1. Flare connection (pipe connection)

5.1.1. Flaring

• Use special pipe cutter and flare tool exclusive for R410A/R32.

(1) Cut the connection pipe to the necessary length with a pipe cutter.

(2) Hold the pipe downward so that cuttings will not enter the pipe and remove any burrs.

(3) Insert the flare nut (always use the flare nut attached to the indoor and outdoor units respectively) onto the pipe and perform the flare processing with a flare tool. Leakage of refrigerant may result if other flare nuts are used.

(4) Protect the pipes by pinching them or with tape to prevent dust, dirt, or water from entering the pipes.

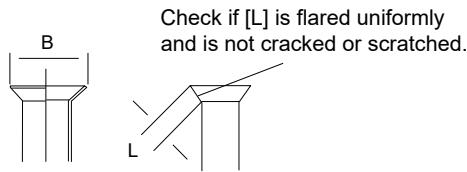

PIPING EXTENSION

Pipe gauge	Tightening torque	Flare dimension (A) (Unit: mm/Inch)	
		Min.	Max.
Ø 6.35	18-20 N.m (183-204 kgf.cm)	8.4/0.33	8.7/0.34
Ø 9.52	25-26 N.m (255-265 kgf.cm)	13.2/0.52	13.5/0.53
Ø 12.7	35-36 N.m (357-367 kgf.cm)	16.2/0.64	16.5/0.65
Ø 15.88	45-47 N.m (459-480 kgf.cm)	19.2/0.76	19.7/0.78
Ø 19.05	65-67 N.m (663-683 kgf.cm)	23.2/0.91	23.7/0.93
Ø 22.22	75-85N.m (765-867 kgf.cm)	26.4/1.04	26.9/1.06

Flare shape

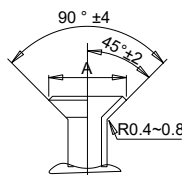

Pipe outside diameter [mm (in.)]	Dimension B [mm]
6.35 (1/4)	9.1
9.52 (3/8)	13.2
12.70 (1/2)	16.6
15.88 (5/8)	19.7
19.05 (3/4)	24.0

When using conventional flare tools to flare R410A/R32 pipes, the dimension A should be approximately 0.5 mm more than indicated in the table to achieve the specified flaring.

5.1.2 Bending pipes

- If pipes are shaped by hand, be careful not to collapse them.
- Do not bend the pipes at an angle more than 90°.
- When pipes are repeatedly bend or stretched, the material will harden, making it difficult to bend or stretch them any more.
- Do not bend or stretch the pipes more than 3 times.

CAUTION

To prevent breaking of the pipe, avoid sharp bends. If the pipe is bent repeatedly at the same place, it will break.

5.1.3. Pipe connection

CAUTION

Be sure to connect the pipe against the port on the indoor unit and the outdoor unit correctly. If the centering is improper, the flare nut cannot be tightened smoothly. If the flare nut is forced to turn, the threads will be damaged.

Do not remove the flare nut from the indoor unit pipe until immediately before connecting the connection pipe.

Do not use mineral oil on flared part. Prevent mineral oil from getting into the system as this would reduce the lifetime of the units.

(1) Detach the caps and plugs from the pipes.

(2) Center the pipe against the port on the indoor unit, and then turn the flare nut by hand.

Connection pipe

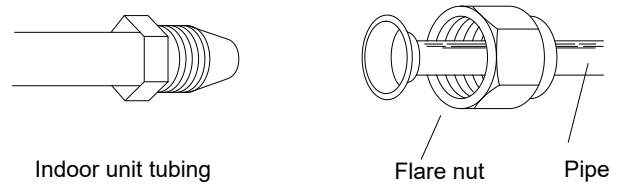

(3) When the flare nut is tightened properly by your hand, hold the body side coupling with a separate spanner, then tighten with a torque wrench. (See the table previous for the flare nut tightening torques.)

6. ELECTRICAL WIRING

WARNING

Electrical work must be performed in accordance with this Manual by a person certified under the national or regional regulations. Be sure to use a dedicated circuit for the unit. An insufficient power supply circuit or improperly performed electrical work can cause serious accidents such as electric shock or fire.

Before starting work, check that power is not being supplied to the indoor unit and outdoor unit. Use the included connection cables and power cables or ones specified by the manufacturer. Improper connections, insufficient insulation, or exceeding the allowable current can cause electric shock or fire.

For wiring, use the prescribed type of cables, connect them securely, making sure that there are no external forces of the cables applied to the terminal connections. Improperly connected or secured cables can cause serious accidents such as overheating the terminals, electric shock, or fire.

Do not modify the power cables, use extension cables, or use any branches in the wiring. Improper connections, insufficient insulation, or exceeding the allowable current can cause electric shock or fire.

Match the terminal board numbers and connection cable colors with those of the outdoor unit. Erroneous wiring may cause burning of the electric parts.

Securely connect the connection cables to the terminal board. In addition, secure the cables with wiring holders. Improper connections, either in the wiring or at the ends of the wiring, can cause a malfunction, electric shock, or fire.

Always fasten the outside covering of the connection cable with the cable clamp. (If the insulator is chafed, electric leakage may occur.) Securely install the electrical box cover on the unit. An improperly installed electrical box cover can cause serious accidents such as electric shock or fire through exposure to dust or water.

Install sleeves into any holes made in the walls for wiring. Otherwise, a short circuit could result. Install a earth (ground) leakage breaker. In addition, install the earth (ground) leakage breaker so that the entire AC main power supply is cut off at the same time. Other-wise, electric shock or fire could result.

Always connect the earth (ground) cable. Improper earthing (grounding) work can cause electric shocks. Install the remote controller cables so as not to be touched directly with your hand.

Perform wiring work in accordance with standards so that the air conditioner can be operated safely and positively. Unit shall be earthen (grounded) in compliance with the applicable local and national codes.

6.1. Wiring method

6.1.1. Connection

Diagrams Connection cable for Non-Inverter Model

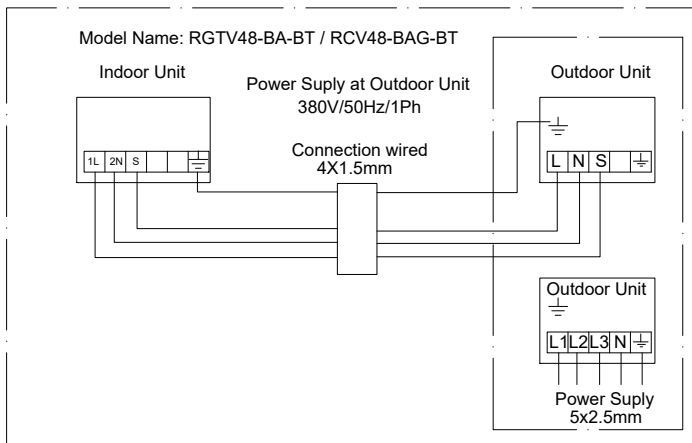
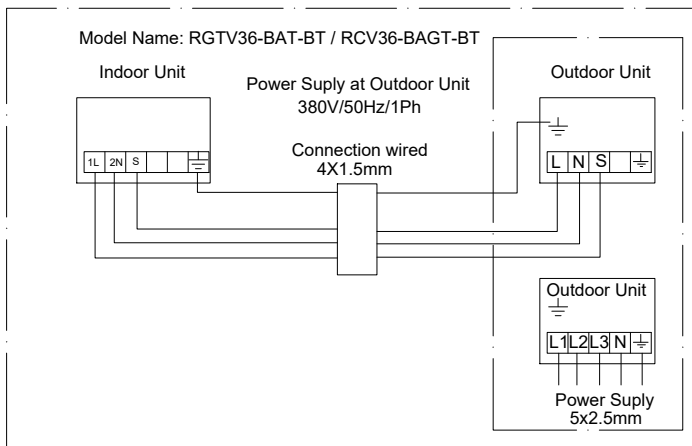
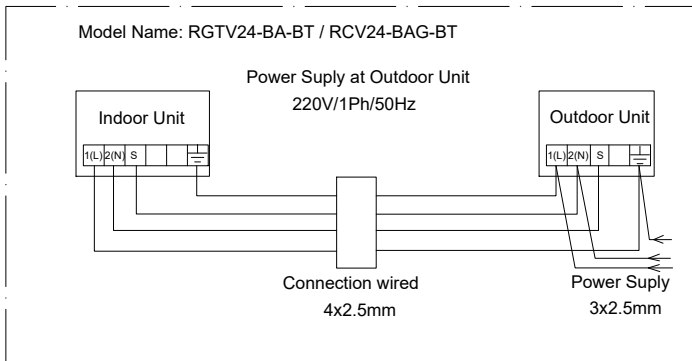
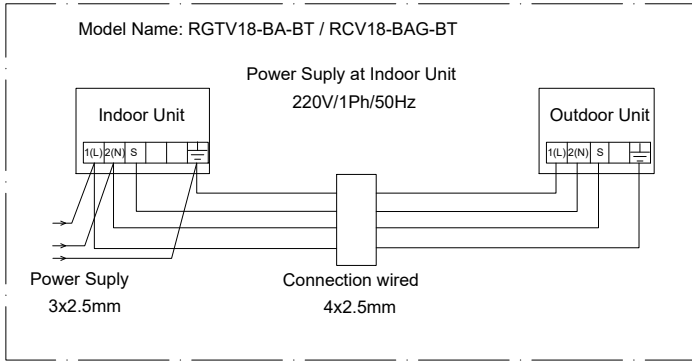

7. OUTDOOR INSTALLATION

7.1 OUTDOOR DIMENSION

MODEL NAME: RCV18-BAG-BT

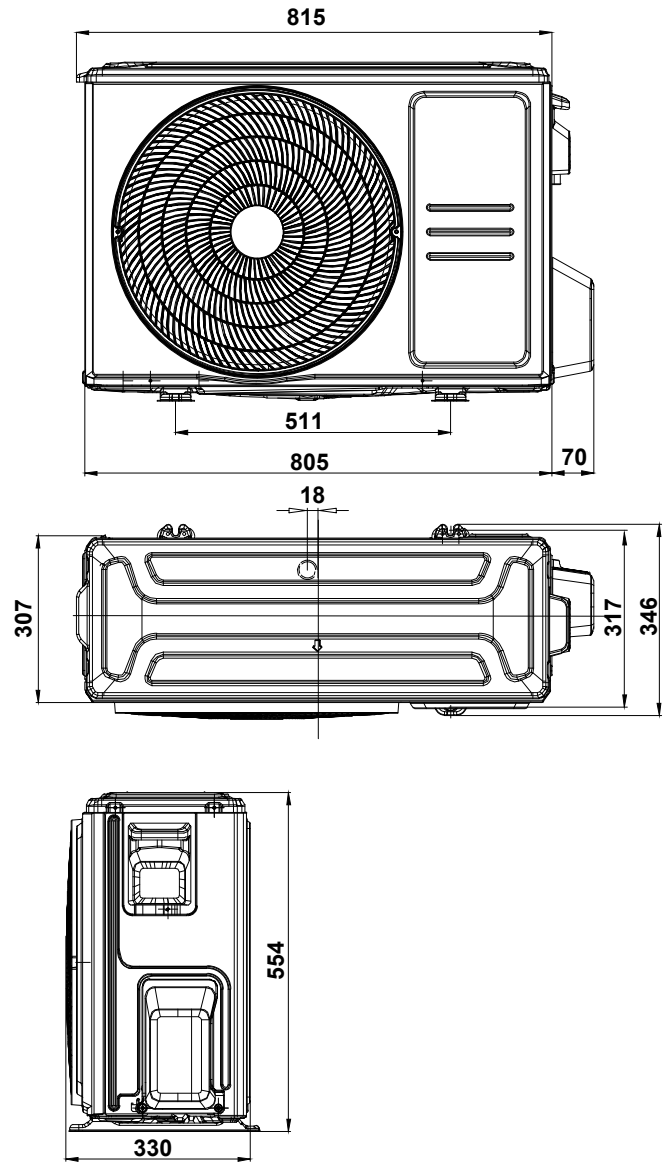

MODEL NAME: RCV24-BAG-BT

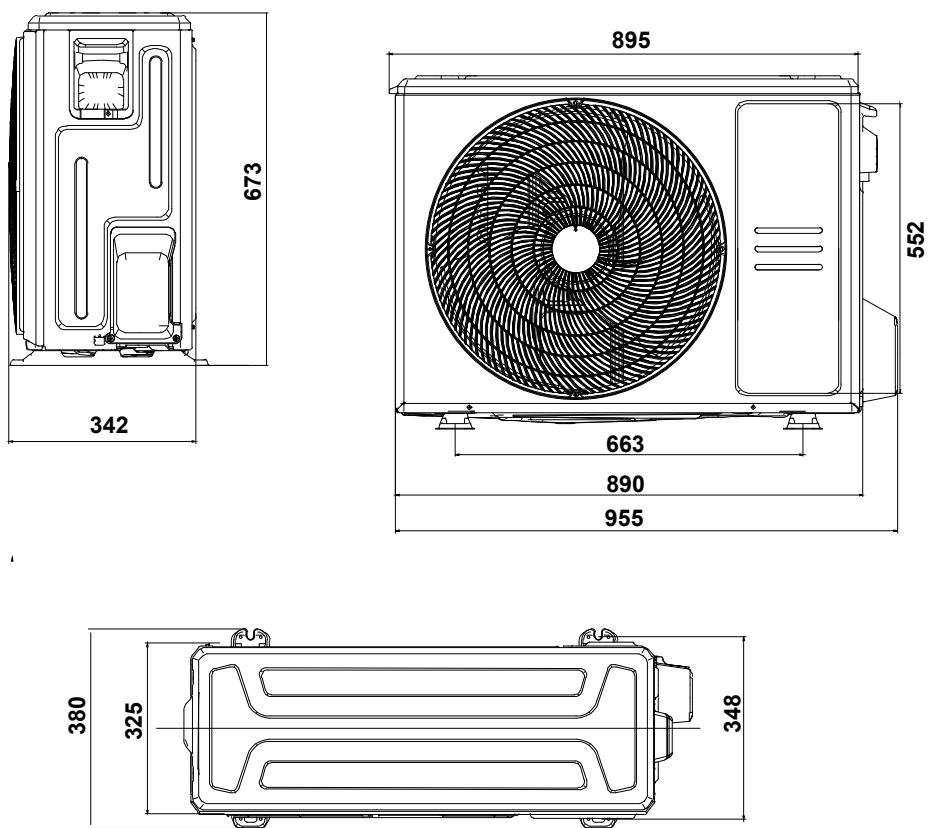

MODEL NAME: RCV36-BAGT-BT / RCV48-BAG-BT

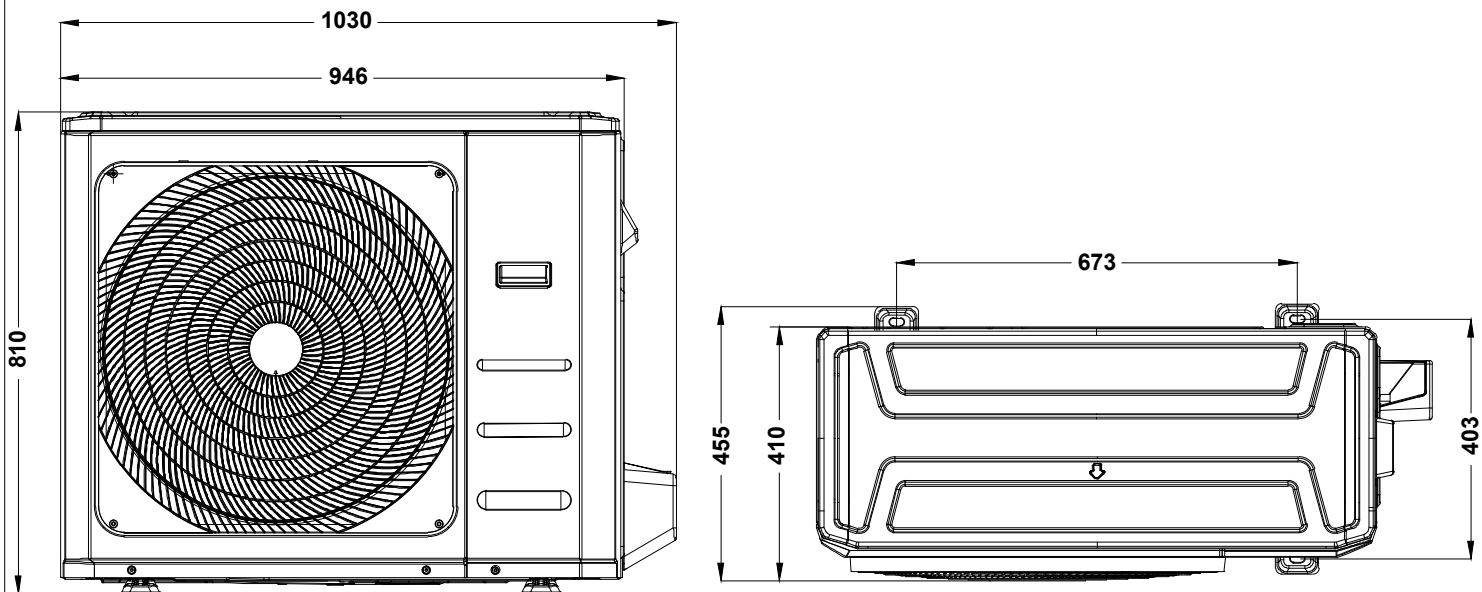

7.1 SELECTING OUTDOOR INSTALLATION POSITION

WARNING

DO NOT install the unit in the following locations:

- Sea side with high salt content in the air. (Contact with authorized services for more information)
- Areas with power fluctuations, such as factories.
- Enclosed spaces
- Electromagnetic waves.
- Store flammable materials or gas.
- Rooms with high humidity, such as bathrooms or laundry rooms.
- If possible, DO NOT install the unit where it is exposed to direct sunlight.

MULTI UNITS INSTALLATION SPACE

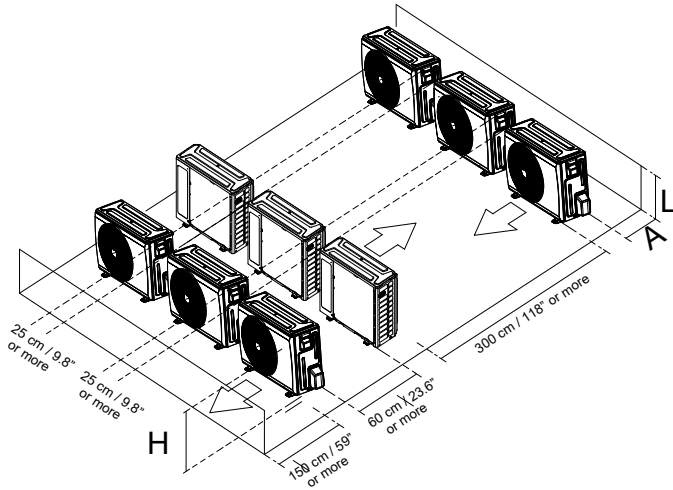

	L	A
L ≤ H	L ≤ 1/2H	25 cm / 9.8" or more
	1/2H < L ≤ H	30 cm / 11.8" or more
L > H	Can not be installed	

SINGLE UNIT INSTALLATION SPACE

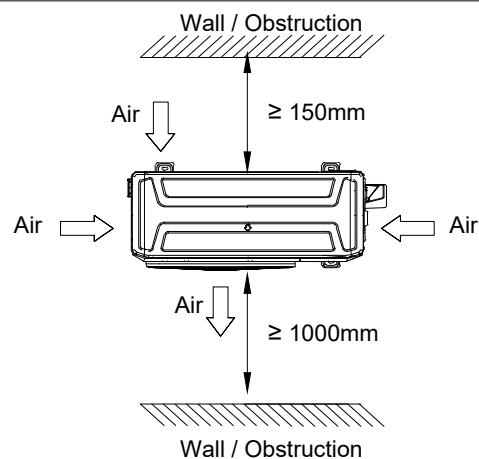
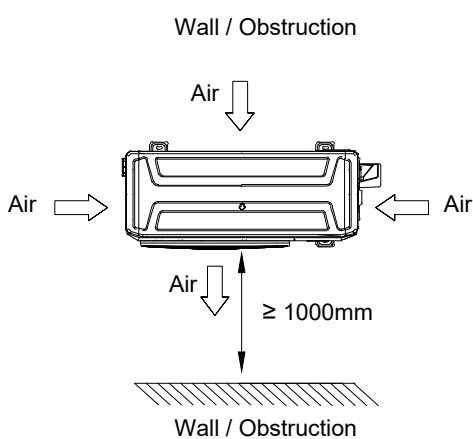
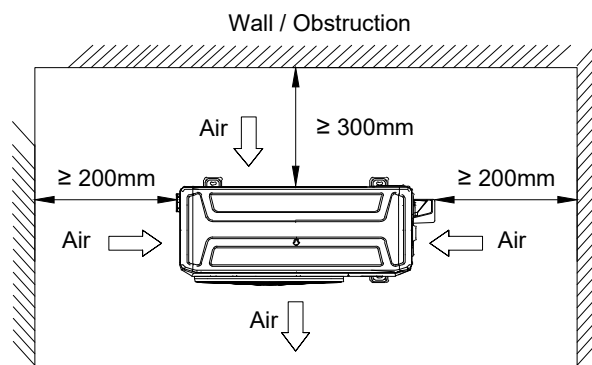
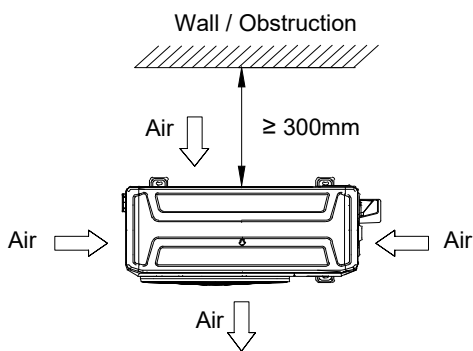

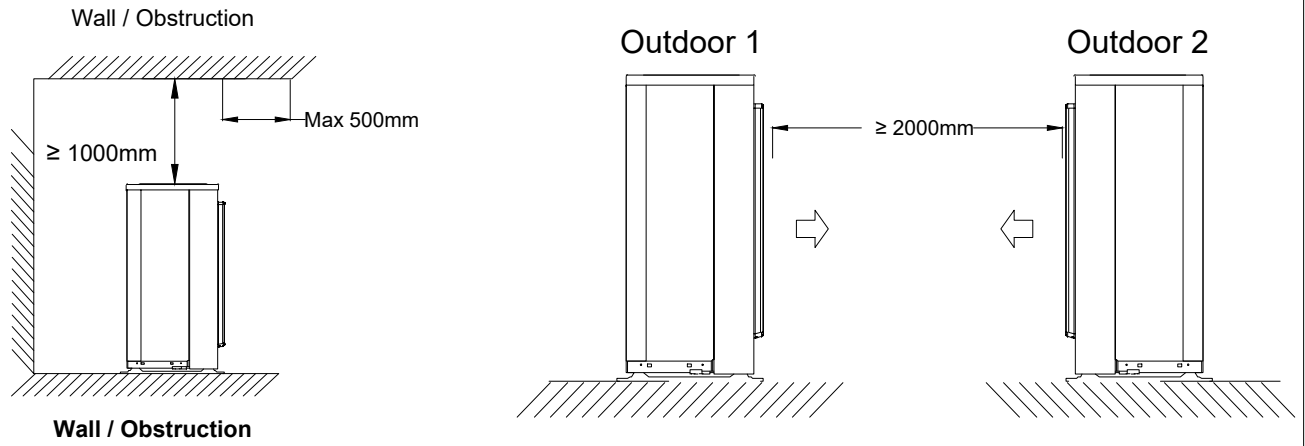

PROHIBITED

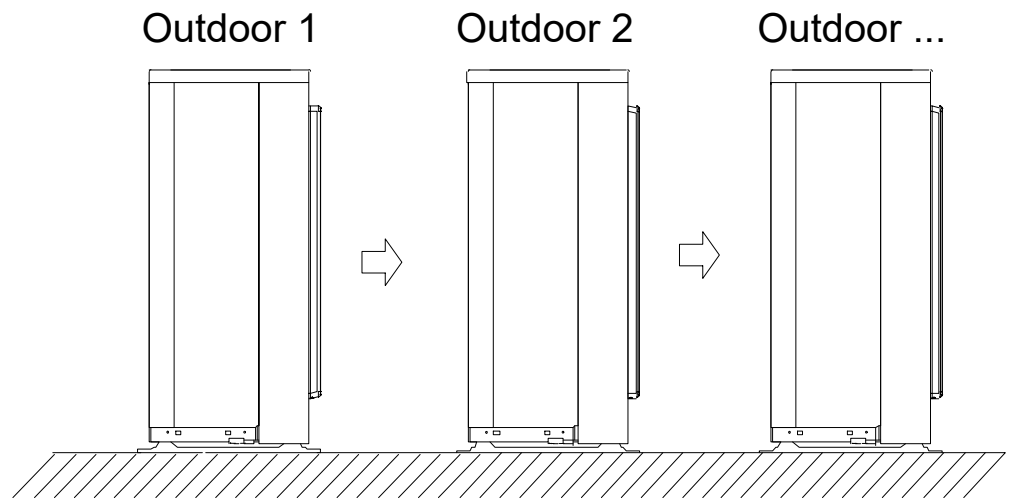

Minimum Cross-Sectional Area of Power and Signal Cables

Rated Current (A)	Nominal Cross-Sectional Area (mm ²)
> 3 and ≤ 6	1.5
> 6 and ≤ 10	2.0
> 10 and ≤ 16	2.5
> 16 and ≤ 25	4.0
> 25 and ≤ 32	6.0
> 32 and ≤ 40	10.0

8.0. CHECK LIST

Pay special attention to the check items below when installing the indoor unit(s). After installation is complete, be sure to check the following check items again.

CHECK ITEMS	If not performed correctly CHECK BOX
Has the indoor unit been installed correctly?	Vibration, noise, indoor unit may drop
Has there been a check for gas leaks (refrigerant pipes)?	No cooling, No heating
Has heat insulation work been completed?	Water leakage
Does water drain easily from the indoor units?	Water leakage
Are the wires and pipes all connected completely?	No operation, heat or burn damage
Is the connection cable the specified thickness?	No operation, heat or burn damage
Are the inlets and outlets free of any obstacles?	No cooling, No heating
After installation is completed, has the proper operation and handling been explained to the user?	

10. CUSTOMER GUIDANCE

Explain the following to the customer in accordance with the operating manual:

- (1) Starting and stopping method, operation switching, temperature adjustment, timer, air flow switching, and other remote controller unit operations.
- (2) Cleaning and maintenance of the product, and other items such as air filters and air louvers if applicable.
- (3) Give the operating and installation manuals to the customer.

9.0. TEST RUN

Operation method

Depending on your installation, choose from the following:

The test operation must be carried out after the entire installation has been completed.

1. Open both the liquid and gas stop valves.
2. Turn on the main power switch and allow the unit to warm up.
3. Set the air conditioner to COOL mode, and check the following points.

Do not operate the air conditioner in test run for a long time.

Check items

1. **Indoor unit**
 - 1.1. Whether the switch on the remote controller works well.
 - 1.2. Whether the buttons on the remote controller works well.
 - 1.3. Whether the air flow louver moves normally.
 - 1.4. Whether the room temperature is adjusted well.
 - 1.5. Whether the indicator lights normally.
 - 1.6. Whether the temporary buttons works well.
 - 1.7. Whether the drainage is normal.
 - 1.8. Whether there is vibration or abnormal noise during operation.
2. **Outdoor unit**
 - Whether there is vibration or abnormal noise during operation.
 - Whether the generated wind, noise, or condensed of by the air conditioner have influenced your neighborhood.
 - Whether any of the refrigerant is leaked.

Drainage Test

- a. Ensure the drainpipe flow smoothly. New buildings should perform this test before finishing the ceiling.
- b. Remove the test cover. Add 2000ml of water to the tank through the attached tube.
- c. Turn on the main power switch and run the air conditioner in COOL mode.
- d. Listen to the sound of the drain pump to see if it makes any unusual noises.
- e. Check to see that the water is discharged. It may take up to one minute before the unit begins to drain depending on the drainpipe.
- f. Make sure that there are no leaks in any of the piping.
- g. Stop the air conditioner. Turn off the main power switch and reinstall the test cover.

Note:In order to improve the quality and improve the product. The specification and details in this document are subject to change without prior notice

11. ERROR CODES

If you use a wired type remote controller, error codes will appear on the remote controller display. For more information, refer to the installation manual of the remote controller. If you use a wireless remote controller, the lamps on the IR receiver unit will output error codes by way of blinking patterns. See the lamp blinking patterns and error codes in the table below. An error display is displayed only during operation.

Operation	Timer	Display	Error Code
1 time	OFF	EH 00/EH 0A	Indoor unit EEPROM error
2 times	OFF	EL 01	Indoor / outdoor unit communication error
4 times	OFF	EH 03	Indoor unit fan motor is abnormal
5 times	ON	EC 51	Outdoor unit EEPROM parameter error
5 times	OFF	EC 52	Heat Exchanger Temperature Error
5 times	OFF	EC 53	Ambient temperature abnormal
5 times	OFF	EC 54	Discharge temperature error
5 times	OFF	EC 55	IGBT temperature error
5 times	OFF	EC 56	Indoor unit outlet air temperature error
6 times	OFF	EH 60	Indoor room temperature error
6 times	OFF	EH 61	Indoor unit temperature error
12 times	OFF	EC 07	Outdoor unit fan motor is abnormal
8 times	OFF	EL 0C	Refrigerant Leakage Detection
13 times	OFF	EH 0E	Water-level alarm malfunction
9 times	OFF	EH	Indoor Unit Communication error
7 times	FLASH	PC 00	IPM malfunction or IGBT over current protection
2 times	FLASH	PC 01	High voltage or over low voltage protection
3 times	FLASH	PC 02	High temperature protection of compressor
5 times	FLASH	PC 04	Inverter compressor error
7 times	FLASH	PC 03	High pressure protection or low pressure protection
--	--	EH A	Communication error between external fan module and indoor unit
4 times	OFF	EH 3A	External fan DC bus voltage is too low protection
4 times	OFF	EH	External fan DC bus voltage is too high fault
1 time	ON	--	Indoor units mode conflict

OPERATION MANUAL

Wireless remote controller specification

Voltage	3.0V (Dry batteries R03/LR03×2)
Distance	8m-11m
Temp. Range	-5 ⁰ C~60 ⁰ C

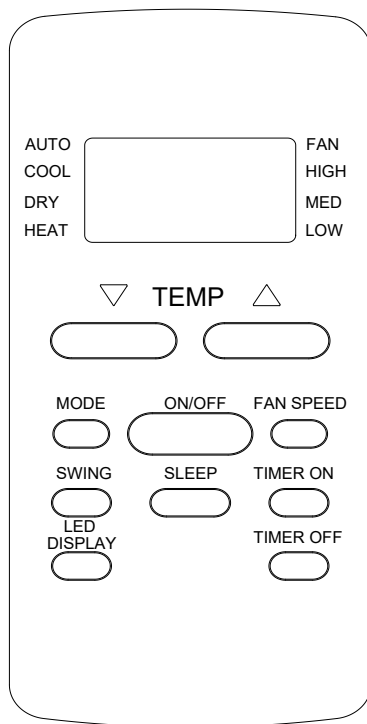

1. TEMP DOWN :

- This function use to decrease the indoor unit temperature setting in 1⁰C increments to 17⁰C

2. TEMP UP :

- This function to increase the indoor unit temperature setting in 1⁰C increments to 30⁰C

3.ON/OFF:

- For turning on or turning off the air conditioner.

4.FAN SPEED:

- Fan speed will be adjusted in following once pressing this button:

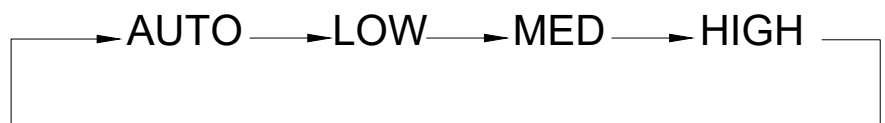

5. MODE:

- Pressing this button, operation mode will be selected in the following:

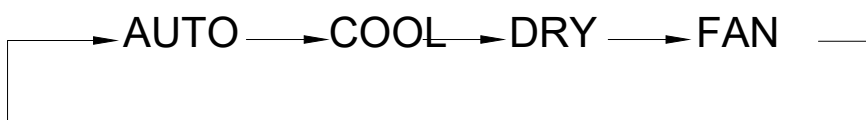

6. TIME ON:

For TIMER ON setting. Press this button to activate the Auto-on time setting.

- Each time it will increase the time setting in 30 minutes increments, up to 10 hours. Then at 1 hour increments up to 24 hours.
- To cancel the Auto-on time setting, just press the button until the time setting is 0.0.

7. SWING:

- To stop or start horizontal louver movement. Hold down for 2 seconds to initiate vertical louver auto swing feature (Optional) .

8. SLEEP:

- Select this function during the sleeping time. It keeps the most comfortable temperature and save energy.
- This function is available on COOL, HEAT or AUTO mode only..

NOTE: While the air-conditioner is operating in sleep mode, it would be cancelled if MODE, FAN SPEED or ON/OFF button is pressed.

9. TIME OFF:

- For TIMER OFF setting. Press this button to activate the Auto-off time setting.
- Each press will increase the time setting in 30 minutes increments, up to 10 hours. Then at 1 hour increments up to 24 hours. To cancel the Auto-off time setting, just press the button until the time setting is 0.0.

10. LED DISPLAY:

- Disable/Active indoor unit display. When pushing the button, the indoor unit display is off. press it again to light the display.